

Type FGWA

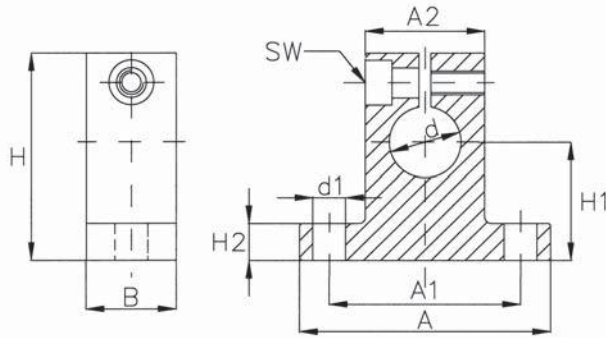

Support aluminium

Référence Type	Dimensions - mm										Poids - Weight
	Ø d	A	B	H	H1	A1	A2	d1	SW	H2	g
FGWA8	8	32	10	27	15	25	16	4,5	M2,5	5	10
FGWA12	12	42	12	35	20	32	20	5,5	M4	5,5	26
FGWA16	16	50	16	42	25	40	26	5,5	M4	6,5	39
FGWA20	20	60	20	50	30	45	32	5,5	M5	8	78
FGWA25	25	74	25	58	35	60	38	6,6	M5	9	135
FGWA30	30	84	28	68	40	68	45	9	M6	10	200
FGWA40	40	108	32	86	50	86	56	11	M8	12	362
FGWA50	50	130	40	100	60	108	80	11	M8	14	740
FGWA60	60	160	48	124	75	132	100	13,5	M8	15	1 400
FGWA80	80	200	60	160	100	170	130	17,5	M10	22	2 750

Type LSCS

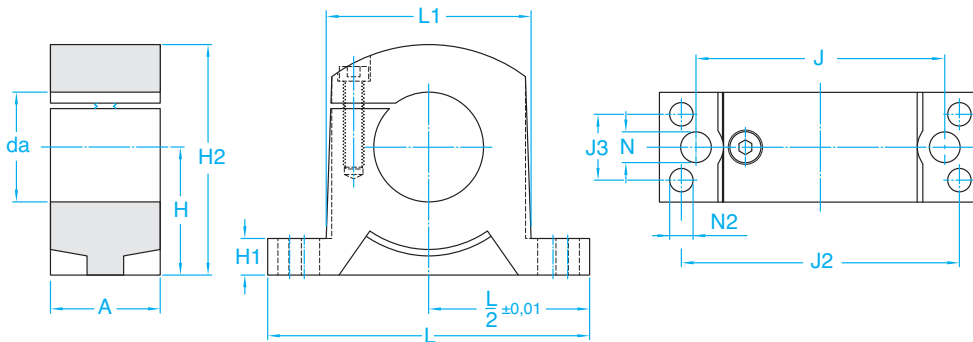

Support aluminium

Référence Type	Dimensions - mm											Poids - Weight	
	da	A	H	H1	H2	J	J2	J3	L	L1	N*	N2	g
LSCS 8	8	10	15	5,5	25	25	35	5	45	19	4,3	2,7	12
LSCS 12	12	12	20	6	32,5	32	42	6	52	25	5,3	3,2	23
LSCS 16	16	15	20	7	35,5	40	46	7,5	56	31,8	5,3	4,3	34
LSCS 20	20	20	25	8	43,5	45	58	10	70	37	5,3	5,3	65
LSCS 25	25	28	30	10	53	60	68	16	80	48	6,4	6,4	140
LSCS 30	30	30	35	10	63	68	76	18	88	56	8,4	6,4	200
LSCS 40	40	36	45	12	81	86	94	22	108	71	10,5	8,4	470
LSCS 50	50	49	50	14	92,5	108	116	30	135	86	10,5	10,5	680
LSCS 60	60	62	60	18	112	132	138	40	160	105	13	13	1 290
LSCS 80	80	85	80	22	147,5	170	180	60	205	136	17	15	3 010

* Pour vis à six pans creux selon DIN 912 / ISO 4762